

# User Manual: **HSW Jet-PACC<sup>one</sup>**

---



## Contents

1.	About this User Manual.....	4
2.	Transport and storage .....	4
3.	General safety advice for operating and cleaning.....	4
4.	General description and information.....	5
a.	Description .....	5
b.	Operating requirements.....	5
c.	Target species.....	5
d.	Mode of action .....	5
e.	Flexible Use Modes.....	6
5.	Packaging contents.....	7
a.	Power Unit.....	8
b.	Connection line (cabel + tube) .....	8
c.	Injection Unit.....	9
6.	Device Start .....	10

7.	Description of the HSW Jet-PACC <sup>one</sup> .....	12
8.	Sensors .....	14
a.	Air detection sensor .....	14
b.	Nozzle Sensor .....	14
9.	Vaccination Process.....	15
a.	Injection Tips .....	16
10.	Device Cleaning .....	17
a.	Rinsing .....	17
b.	Storing the device.....	18
c.	Cleaning of the power unit.....	19
d.	Cleaning of the Injection unit .....	19
e.	Cleaning of the Connection line .....	20
11.	Troubleshooting .....	21
a.	Guidance.....	21
b.	Air Detection Override .....	22
12.	Maintenance and Repair .....	28
a.	Preparation servicing and maintenance.....	28
b.	Preventive Maintenance .....	29
c.	Cylinder Service after 36.000 injection .....	29
d.	Cleaning and checking the outlet valve in the injection unit .....	32
e.	Cleaning and checking the fluidsensor and inlet valve .....	33
13.	Dismantling.....	35
14.	The battery and the charger.....	36
a.	Battery .....	36
b.	Charger .....	37
15.	Spare Parts.....	38
16.	HSW Connect App .....	41
17.	Technical Specifications.....	42
18.	Disposal .....	42
19.	UKCA – Conformity marking.....	42
20.	EC declaration.....	43
21.	FCC Regulatory Compliance .....	44
22.	Industry Canada (IC) regulatory information .....	44
23.	SRRC Compliance Statement (China) .....	45

## HSW Jet-PACC<sup>one</sup> Manual

This user manual is part of the HSW Jet-PACC<sup>one</sup> device and an important part of the safe usage concept.



- Read the user manual carefully and follow the instructions –

© copyright · Henke-Sass, Wolf GmbH · 800021024–04/25 · Subject to amendments in technology and design · Printed in Germany

### Explanation packaging symbols

#### eIFU:



This symbol indicates that a digital instruction manual is available for this this syringe. The digital instruction manual can be found by scanning the QR code shown on the right side.



#### Recycling codes:

The recycling codes provide information about the material used and can be helpful for waste separation.



The letter abbreviation PAP identifies cardboard and paper.  
PAP 21= Other cardboard

 The HSW Jet-PACC<sup>one</sup> device is manufactured by:

Henke-Sass, Wolf GmbH  
Keltenstrasse 1  
78532 Tuttlingen  
Germany

Tel. +49 74 62 94 66 0  
Fax +49 74 62 94 66 52 08  
www.henkesasswolf.de  
E-mail: info@henkesasswolf.de

## 1. About this User Manual

While reading the user manual you will see that it includes warning signs, to alert you to risks arising from incorrect usage of the product that could result in death, injuries or material damage. Always take careful note of these warnings! The warning signs are highlighted as shown on the right.



## 2. Transport and storage

Protect the product against external forces (e.g. impacts, shocks and knocks) at all times, including during transport.

Check the HSW Jet-PACC<sup>one</sup> for any transport damage before use.

Transport and/or store the HSW Jet-PACC<sup>one</sup> in its original packing.

Store the HSW Jet-PACC<sup>one</sup> so that it is protected from sunlight.















In case of storage for longer than 12 months, follow the steps in this user manual (see Troubleshooting chapter) to start-up the device.

To avoid deep discharge of the battery, it should be fully charged once every 6 months.

Do not store the batteries at temperatures lower than 5°C.

Never store the HSW Jet-PACC<sup>one</sup> in a wet or humid condition (e.g. directly after cleaning).

## 3. General safety advice for operating and cleaning

-  Direct contact between the vaccine and/or rinsing fluid and the eyes and/or respiratory tract of the operator can be harmful. In these cases, seek immediate medical advice and show the vaccine information sheet.
-  Use the HSW Jet-PACC<sup>one</sup> for injecting **animals only** .
-  Keep children out of the operating area.
-  **Do not immerse the HSW Jet-PACC<sup>one</sup> in any liquid.**
-  **Do not autoclave the HSW Jet-PACC<sup>one</sup>.**
-  **Do not sterilize the HSW Jet-PACC<sup>one</sup> in an UV box, nor any other sterilization device (i.e. EO-sterilization or gamma radiation).**
-  Do **not** point the **HSW Jet-PACC<sup>one</sup>** towards any part of your body or towards other people! In case of accidental injection of vaccine and/or rinsing fluid, seek immediate medical advice and show the vaccine information sheet.
-  Beware of the spike in the bottle holder. It is very sharp and may contain residues of the vaccine and/or rinsing fluid. In case of a spike wound, seek immediate medical advice and show the vaccine information sheet.
-  Wear safety goggles and a mask when using the HSW Jet-PACC<sup>one</sup>. Ensure goggles are clean for optimal vision.
-  Wear rubber gloves when cleaning the HSW Jet-PACC<sup>one</sup>.
-  Do not throw the battery into water. Protect the battery from water and humidity, which could cause it to leak and release hazardous substances.
-  Do not throw the battery into fire, nor heat the battery. It may explode and/or release hazardous substances.
-  Do not expose the battery to temperatures higher than 60°C. It may explode and/or release hazardous substances.
-  Only veterinary practitioners or operators / farmers instructed by an HSW Jet-PACC<sup>one</sup> user are permitted to work with the HSW Jet-PACC<sup>one</sup>

- ⚠ Dropping the device while it is loaded with liquid may cause an unintended release and irreparably damage the device.
- ⚠ To prevent leakage, reduce the pressure inside the bottles by piercing them with a sterile needle prior to mounting a bottle on the device. Hold the bottleholder of the HSW Jet-PACC<sup>one</sup> upside down when mounting a new bottle.
- ⚠ When expelling residual vaccine or rinsing fluid from the device, always position the needle into a bottle. Never inject into the air.
- ⚠ Operating the HSW Jet-PACC<sup>one</sup> for a longer period of time may induce cramps in the operator's hands. Regular breaks are recommended.

## 4. General description and information

### a. Description

The HSW Jet-PACC<sup>one</sup> is a **needle-free, electronic veterinary injection system** designed for the **intramuscular administration of injectables**. It features **precise volume control (0.5 or 1ml/ 2 ml)**, a **lightweight handpiece with dual-safety trigger**, and a **wearable drive unit**. The injection is performed **without a needle**, using high-pressure fluid jet technology to deliver vaccines safely and painlessly. With **cycle times under 1 second**, **IP56 protection**, **Bluetooth connectivity**, and **user-replaceable components**, the system ensures fast, hygienic, and traceable mass vaccination in modern livestock operations.

### b. Operating requirements

Please read the user manual carefully before first use.

### c. Target species

The HSW Jet-PACC<sup>one</sup> is suitable for a wide range of animals. It is ideal for routine vaccinations, disease prevention campaigns, and individual treatments, offering the possibility of needle free intramuscular applications. Please check with your veterinary for the injection quality.

### d. Mode of action

This advanced veterinary injection device is a needle-free, electronically controlled system designed for intramuscular administration of vaccines. It combines high-precision dosing, rapid cycle times, ergonomic handling, and digital connectivity with cutting-edge needle-free injection technology.

A vaccine bottle is inserted to the bottle holder, which can be attached either to the drive unit or worn on the user's body. The vaccine is delivered via a durable, easy-to-clean hose-cable assembly to the injection system. An integrated fluid detection sensor ensures that no air is aspirated or injected. The desired injection volume is selected via a display with two control buttons on the drive unit.

The system uses a high-pressure nozzle to inject the vaccine as a focused fluid jet directly through the skin into the muscle tissue. The required penetration depth needs to be checked individually to the scenario.

After each injection, the system automatically reloads the next dose using a digitally controlled piston mechanism. The entire injection cycle (loading + injection) is completed in under 1 second, allowing for fast batch treatment.

The injection is triggered via a dual-safety mechanism (guard + trigger) on the handheld unit. Haptic (vibration) and visual (LED) feedback confirm successful injection directly on the handpiece.

The system supports Bluetooth communication with the HSW Connect App which allows generation of vaccination records, device checking easily possible and updates.

All critical components are user-replaceable without special tools. The service unit with the sealing system is rated for 36,000 injections. Exchanging the service unit ensures consistent injection force across its lifetime.

This device represents the next generation of veterinary injectors: needle-free, precise, fast, ergonomic, and digitally integrated. It reduces animal stress, enhances hygiene and safety, and enables streamlined operation and maintenance — making it the ideal solution for modern livestock vaccination protocols.

#### e. Flexible Use Modes

The device allows most flexibility to achieve the best vaccination experience needed. The modular setup allows the drive unit to be used in three different configurations:

- **Backpack Solution:** The drive unit can be carried ergonomically on the user's back using a comfortable harness system, allowing easy mobility in pens or barns while keeping the hands free for safe animal handling.

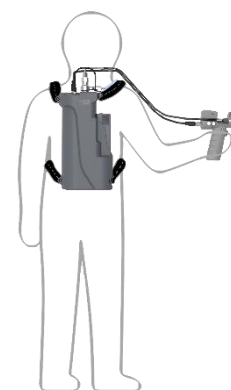

- **Belt-Mounted Solution:** The compact drive unit can be worn at the waist with a belt or shoulder strap, ideal for mobile, hands-free use during high-throughput vaccination in the field.

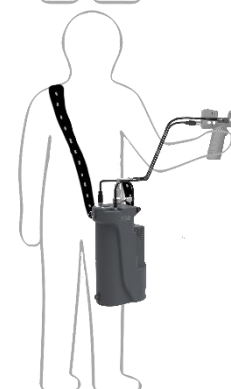

- **Stationary Trolley Setup:** For clinic or stable environments, the drive unit can be mounted on a flexible treatment cart equipped with wheels and accessory storage. This setup provides continuous operation with minimal user fatigue, perfect for stationary mass treatment scenarios.

All configurations support the same needle-free injection performance, fast cycle times, Bluetooth connectivity, and ergonomic handpiece use. The system adapts seamlessly to diverse working environments — whether in mobile on-farm settings or stationary treatment stations.

## 5. Packaging contents

Description	Number	Amount	
Power unit	8300065977	1	
Injection unit	8300066472	1	
Connection cable	8300066483	1	
Connection tube incl. angle piece	8300066204	1	
Cable Clip 2-way	8300066482	5	
Battery 5S1P 18V	8300067446	2	
Charger 18V	8300067859	1	
Bottle PET 250ml + Cap	8300019267 8300017876	1	
Lubrication oil 10ml bottle	8300027303	1	
Silicon Tubing 2m	3532000600	2m	
Back straps	8300067496	1	
Bottle net 250ml	8300067497	2	
Snap hook	8300067498	1	
Draw-Off Cap white 20mm, 50-100ml	3600000020	1	
Draw-Off Cap blue 30mm, 250-500ml	3600000030	1	
Draw-Off Cap green 33mm, > 500ml	3600000033	1	
Threaded bottle adapter to hose	8300067772	1	
Wrench for Jet-PACC	8300068054	2	
Spare cylinder	8300065482	1	
Spare part set (valve + O-ring)	8300067768	1	
Hose clamp	8300068944	1	
Waist strep	8300069346	1	

a. Power Unit

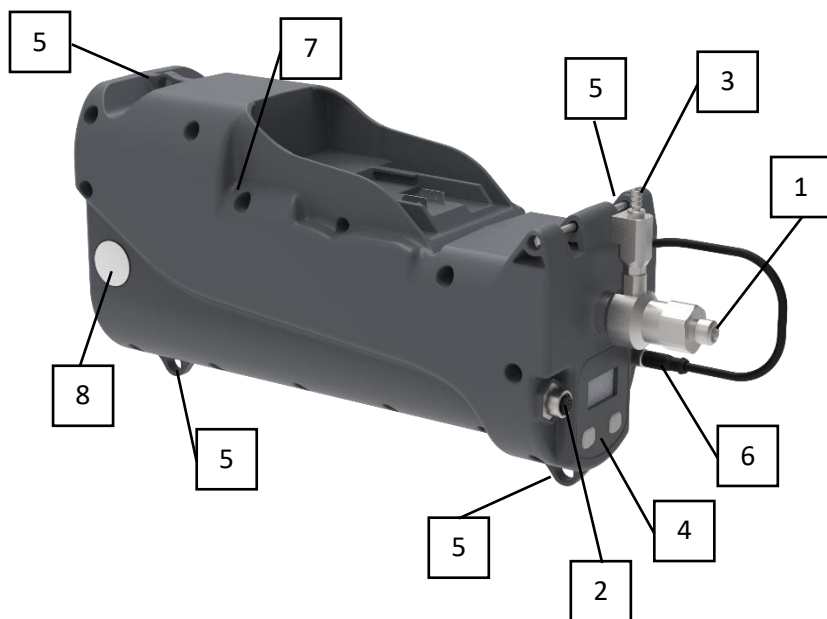

Part	Description
1	Pressure Tube connection
2	Cabel connection
3	Injectable Tube connection
4	Display with buttons
5	Connection for back straps
6	Fluidsensor cable
7	Battery connection
8	Pressure compensation element

b. Connection line (cabel + tube)

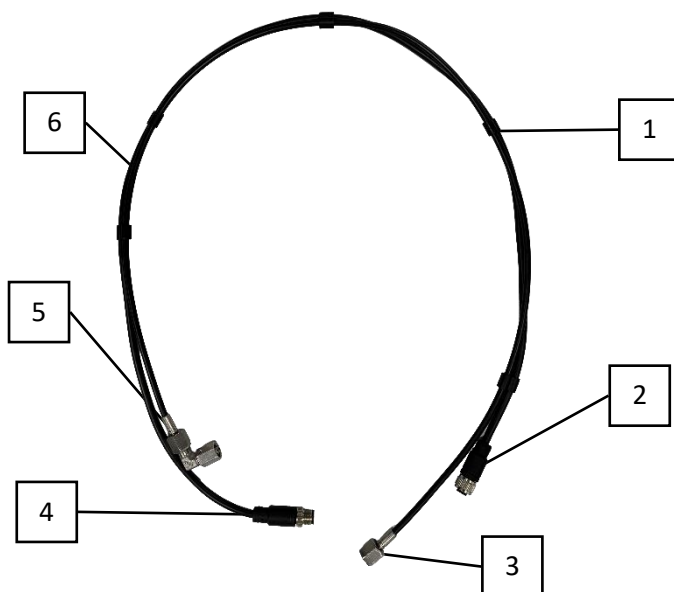

Part	Description
1	High Pressure Tube
2	Electrical connection Injection unit
3	High pressure tube connection Injection unit
4	Electrical connection Power unit
5	High pressure tube with angel piece connection Power unit
6	Electrical cabel

### c. Injection Unit

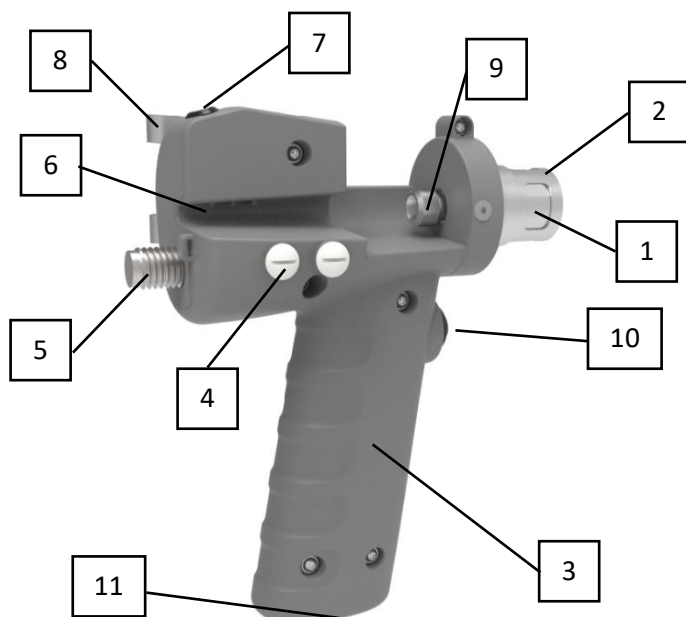

Part	Description
1	Injection Nozzle
2	Safety Cage
3	Handel
4	Thread for Belt Clip
5	Cabel connection
6	Fixation for Injectiontube
7	Status LED
8	Belt Clip
9	Injectable Tube connection
10	Trigger button
11	Thread for Stationary mounting

Status	LED Color	Haptic Feedback	Description
<b>1. Priming / Rinse Mode</b>	Blue, solid <span style="color: blue;">●</span>		Device is preparing or flushing
<b>2. Ready / Dose Loaded</b>	White, pulsing <span style="color: white;">○</span>		Device is ready to inject
<b>3. Volume Adjustment Mode</b>	Yellow, slow blinking <span style="color: yellow;">●</span>		Dose volume is being changed
<b>4. Successful Injection</b>	1× Green blink (approx. 0.5 sec) <span style="color: green;">●</span>	1× short pulse	Injection completed successfully
<b>5. Injection OK + Vial Nearly Empty</b>	1× Green blink → Orange blinking <span style="color: green;">●</span> <span style="color: orange;">●</span>	1× short pulse → after 1 sec: 2× short pulses	First confirmation of success, then vial warning
<b>6. Early Trigger Press / Misfire</b>	Red, fast blinking (2 times) <span style="color: red;">●</span>	2× double pulse	Cage released too early or incompletely
<b>7. Air Detected in System</b>	Red, medium-speed blinking <span style="color: red;">●</span>	Pulsing	Air detected
<b>8. Critical Error / System Failure</b>	Red, blinking (continuous) <span style="color: red;">●</span>	Continuous pulsing	Critical failure – refer to troubleshooting guide immediately

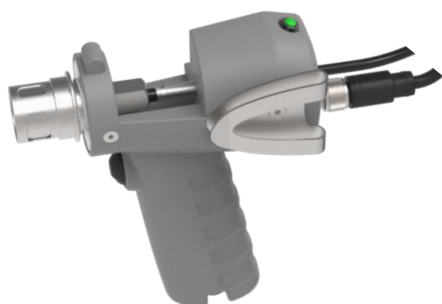

## 6. Device Start

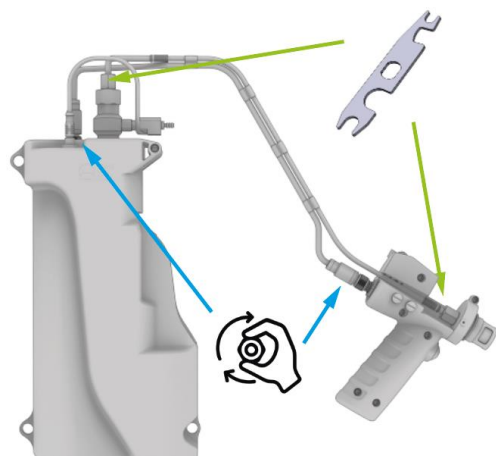

Connect the Connection line (cabel + tube) with the power unit and then with the injection unit. Please use the supplied multitool or a wrench with 15 mm.

Make sure that the cable is mounted only hand tight.



Depending if you are right or left handed you can mount the Connection tube incl. angle piece to the right or left side.



Puncture the bottle bevor to release the overpressure and connect the injectable with the correct draw off cap. Depending on your bottle chose the right adapter.

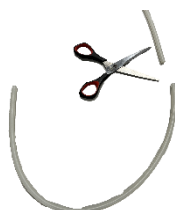

Choose the right length for the silicon tube for your setup. We recommend the following length for the following setup:

- Backpack Solution 55cm
- Belt-Mounted Solution 45 cm
- Stationary Trolley Setup 20 cm  
(This is only needed for the first setup and a recommendation)

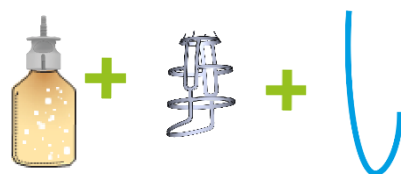

Insert the bottle in the bottle holder and then connect to the silicon tube.



Fill the connected tube till all air is out and connect then to the tube connector of the power unit.

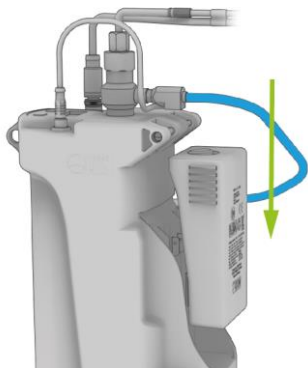

Connect the battery to power unit and turn on the device.



Choose the desired volume by pressing the right button to switch to the Volume choosing mode. Press the left button to change the volume.

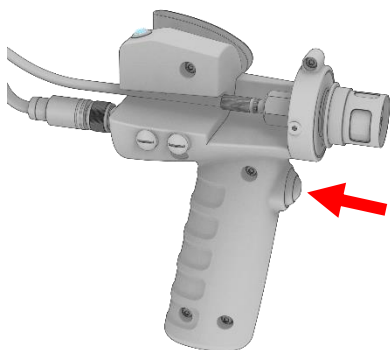

Press the trigger of the injection unit. The device will rinse min. three times till the system is completely filled with injectable.

When the LED shows a white blinking the device is loaded and **ready for injection**.



Mount the injectable tube as you need it, make sure the tube is long enough to have free movement of the bottle to make sure always to suck in liquid.

## 7. Description of the HSW Jet-PACC<sup>one</sup>

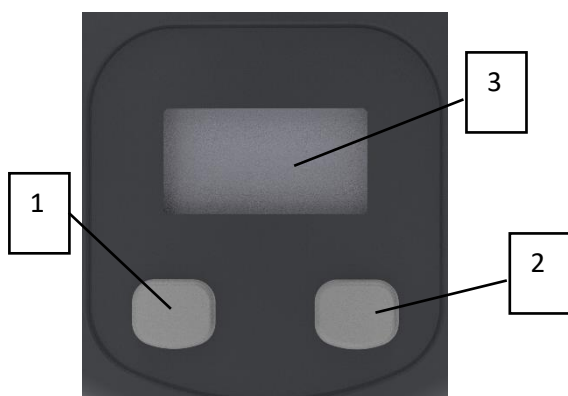

Description	
1	Left Button
2	Right button
3	Display



When the battery is inserted correctly (right direction), the display will show the HSW Logo and afterwards the home screen. Make sure you have attached a bottle with injectable.

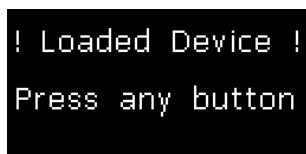

If the device is loaded (i.e., the cylinder is filled with vaccine or rinsing fluid), the display will show: “! Loaded Device ! Press any button”, and the LED bars will flash red.

To prevent unintentional injections, do **not** press the trigger unless you intend to administer a dose. Do **not** store or power off the device while it is loaded.



When the device is starting up it will ask you, if you want to start a new session. By pressing the left button No it will continue the old session. By pressing the right button Yes it will start a new session. If you press the trigger it would be the same as the left button No. (Here, there may be a waiting time when starting a new session.)

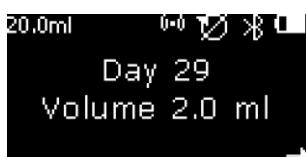

The home screen of the User Menu will show the most relevant information in its middle, like day counter and currently set volume. Furthermore, the start display shows at the top edge, from left to right: vial level counter, haptic feedback, selected mode, Bluetooth and battery level.



To proceed to the menu pages push the right button. the first number indicates the number of successful vaccinations for the day and the second number in parentheses indicates the number of all shots performed during the day, including the early releases. To reset the day counter, push and hold the left display button for two (2) seconds.



On the second page, the volume can be adjusted. The currently set volume is shown in the center, the optional volume is shown on the lower left side. Push the left display button to choose the optional volume. The dose will be changed only upon usage of the device (after the priming cycles and before the first injection). The display will show the information “Changing Volume for vaccination” and flash yellow. After the information disappeared vaccination can be started.



The third page shows the Service Counter, which is counting from 36,000 to 0. If the value falls below 0, the counter continues counting negatively. Push and hold the left display button for two (2) seconds to reset the service counter. Attention: Do not reset the counter until the cylinder service with cylinder change has been performed.

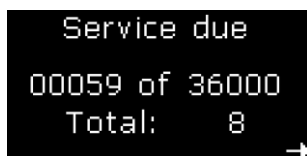

A 'Service due' message appears after there have been 36,000 or more injections, showing that a cylinder service needs to be performed.



The fourth page shows the Total Counter, which counts the total number of injections. This counter cannot be reset as it is a key indicator for the age of the device.



The last page shows the submenu "Settings". Enter the submenu with the left display button. Pushing the right display button returns the screen to the home screen (see above).

### Submenu "Settings":



The haptic feedback can be controlled. Push the left display button to disable (Off) or enable (On) the haptic feedback which will confirm the injection.



The Vial Level Indicator can be controlled. This indicator will give an optical and haptic warning (via the haptic motor, via yellow LED and in the display there will be a warning to check the vial) once you have 5 doses left inside the connected bottle. This allows for a better overview on when to change a bottle during the vaccination session. To activate the vial level indicator, choose the size of the bottle / canister you want to mount by pushing the left display button (0ml, 20-50ml (intervals of 5), 50-500ml (intervals of 50) and 500-5000ml (intervals of 500)).

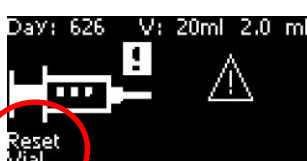

For resetting the vial counter press the left display button or by activating the contact sensor two (3) times in 1 seconds.

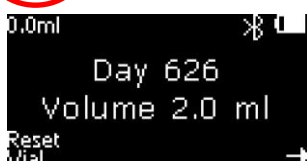

**CAUTION:** The vial level indicator is a simple counter that needs to be set up according to the bottle size mounted to the device. It counts backwards from the set volume to zero, the current counter reading is shown in the top left of the display.



Since we cannot control how the HSW Jet-PACC is used in the field, the display orientation can be flipped by pressing the left button. The button layout remains unchanged.



You can choose the vaccination mode between "Reload continuously" or "Reload intent". This means, that in the continuously mode you can hold the trigger button and the next dose is reloaded automatically. In some cases you don't want to and need to release the trigger button to activate the next reload.



The date and time can be changed via the left button.

The language can be changed by pressing the left button. Please check whether your desired language is available. If not, ensure that your device is running the latest software version via the app. New languages may be added with future software updates.

The sessions can be viewed or closed with this option.

If the sessions has not closed in the starting screen you can later close the open session here.

In the sessions are the following stored from left to right:  
 Injections, rinsing cycles, Date and time from start of the session.  
 Injection quality, Cleaning cycles of the device, Date and time end of the session.

On the last page, the serial number e.g. 2222229 and the software version is shown. Push the right display button to return to the “Settings” page of the user menu. Push the right display button again to reach the home screen of the user menu.

## 8. Sensors

The HSW Jet-PACC<sup>one</sup> device is equipped with several sensors to guarantee an optimal vaccination result.

### a. Air detection sensor

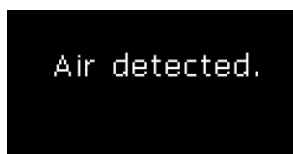

This sensor measures whether fluid or air is drawn into the device. If air is drawn in, e.g. by emptying the bottle and not fitting a new one in time, a warning “Air detected” is shown. Afterwards, only rinsing is possible, indicated by blue LED, until the air exits at the injection head. This takes a minimum of 3 rinsing cycles, as the liquid circuit has a volume of a little less than 6 ml and one rinsing cycle moves a volume of 2 ml. After the rinsing process, you will be able to vaccinate again (indicated by white flashing LED).

### b. Nozzle Sensor

This sensor enables an extra safety precaution when using the injector. Once the device is ready for vaccination (white flashing LED), push and hold the trigger. When the device is applied to the skin of the animal, the safety sleeve around the injection head will slide back, releasing the vaccine. If either

the trigger is not pushed or the safety sleeve around the injection head does not slide back, no vaccine will be released. This enables a high level of user safety.

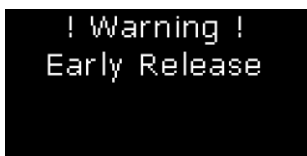

Furthermore, the nozzle sensor measures if the minimum contact time between device and animal **for administration of the full dose** is fulfilled. If the injector is released too early from the skin of the animal, implicating an underdose, the device will give an optical and haptic warning via red flashing LED and a written notification on the display as well a haptic feedback in the handle.

## 9. Vaccination Process



At the first run of a new session or after every restart of the device, the device will be rinsed for three (3) times by pulling the trigger, to flush out remaining rinsing fluid inside the system and to fill the cylinder with vaccine. **No vaccine will be wasted during this procedure** as approximately three (3) doses of liquid fit into the liquid circuit of the device. The display will let you know, once the third and last rinsing cycle is completed. Rinsing is indicated by a **blue light LED**. If you are changing the battery and the changeover between removing the empty battery and inserting the new one takes less than 5 minutes, the rinsing will be skipped as vaccine is already in the device.

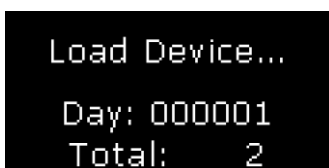

After three (3) rinsing cycles, push and hold the trigger to load the device for the first injection. During loading, "Load Device" is displayed.

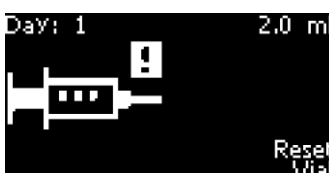

After loading, the device is ready to vaccinate, which is indicated by a **white flashing LED** and an illustration of a syringe on the display. At this stage, (a) the first injection cycle can be started, (b) another rinsing cycle can be carried out or (c) the vial level indicator can be reset.



With option (b) above, another rinsing cycle can be carried out by pushing one of the display buttons and **simultaneously** pushing the trigger. If the dose is set to lower 2ml, the device will automatically change the volume back to 2 ml for rinsing. If the dose is set to 2 ml, rinsing will be carried out without a change of volume.

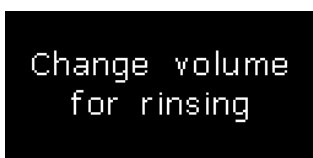

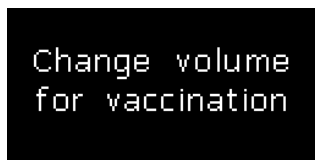

The device will automatically switch back to the set dose after the rinsing cycle, which is indicated by yellow flashing LED bars. This is only relevant when the dose was set to lower 2 ml prior to rinsing.

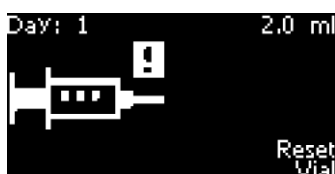

For the option (c) above, to reset the vial level indicator, push the right display button **without** simultaneously pushing the trigger.

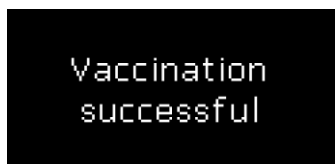

In option (a), an injection cycle is released once the trigger on the handle is **pushed and held** while counter-pressure is generated on the safety sleeve around the injection head (the two-way security mechanism) by applying and pushing the injection head onto the skin of the animal.

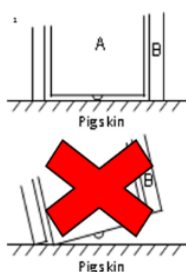

- a) Push and hold trigger on the handle of the device.
- b) Apply the injection head (A) to the skin of the animal **perpendicularly (!)**, add a certain pressure to make the safety sleeve (B) move backwards and release the injection.
- c) During injection, the display will indicate that the device is currently injecting by showing “Vaccination”. During this time, make sure that the nozzle of the device stays pushed onto the skin of the animal perpendicularly.
- d) The device will indicate that the injection was administered successfully by a **green light LED** and a notification on the display and a short pulse in the handle. If the device was removed from the skin of the animal too early, the device will indicate this by a **red light LED and a double impulse in the handle**. Thus, the classification into good or bad injection is based on a time measurement.



After each injection, release the device from the skin of the animal to enable the next loading cycle and injection. When kept in contact with the animal’s skin **after** an injection and still reloading, the device will show “Please release Nozzle” before another injection can go into the same animal by mistake. Additionally, the LED bars will flash white and red in alternation. After releasing the nozzle from the animal, the alternating LED signal will continue to appear, nonetheless you can continue with the next injection.

By keeping the trigger **continuously pushed**, HSW Jet-PACC<sup>one</sup> automatically prepares itself for the next vaccination. The next animal can now be vaccinated by pushing the nozzle against its skin. Caution: Continuously pressing the trigger results in bypassing the double safety mechanism and the risk for unintentional release of an injection is present.

### a. Injection Tips

A small amount of vaccine may remain visible on the animal’s skin after vaccination. This is normal with needle-free intramuscular vaccination and does not affect proper vaccine delivery. In some cases, a higher amount of residue may occur, for example due to insufficient cleaning of the fluid path, loose connections, excessive pressure on the injection head, or the use of highly viscous vaccines without proper cleaning and lubrication.

## 10. Device Cleaning

### a. Rinsing

- ⚠ The cleaning procedure described below must be carried out after each vaccination session and before changing to another injectable, unless the injectable manufacturer provides stricter instructions.
  - ⚠ For routine internal cleaning of the fluid path, especially after oil-adjuvanted, emulsion-based, viscous or polymer-containing vaccines, use demineralized water mixed with a small amount of mild, pH-neutral hand dishwashing liquid.
  - ⚠ Do not use dishwasher detergent. Dishwasher detergents may contain aggressive alkaline components and are not suitable for cleaning the internal fluid path.
- Leave the battery attached to the device.
  - Disconnect the vaccine bottle (vial)

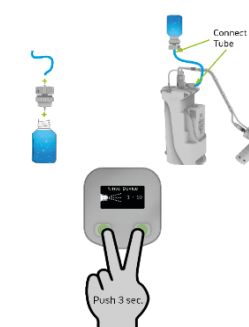

Connect a bottle with clear demineralized water or PBS to the device and run one rinsing program to remove remaining vaccine from the fluid path

Start the rinsing program by pushing both display buttons at the same time for 3 seconds. The device will automatically perform ten (10) rinsing cycles in a row. This process starts only when the device is not loaded and the home screen is shown.

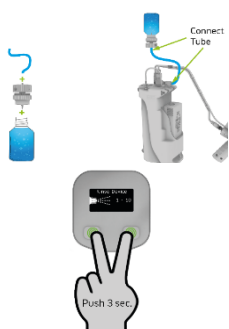

Connect a bottle with demineralized water **mixed** with a small amount of mild, pH-neutral hand dishwashing liquid, using the supplied 250 ml PET bottle and threaded bottle adaptor.

Start the rinsing program by pushing both display buttons at the same time for 3 seconds. The device will automatically perform ten (10) rinsing cycles in a row. This process starts only when the device is not loaded and the home screen is shown.

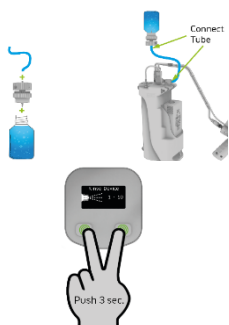

Disconnect the detergent solution and connect a bottle with clear demineralized water or PBS.

Start the rinsing program again with at least ten (10) rinsing cycles to remove all detergent residues from the device.

Check that a clean and continuous jet exits the injection head and that no foam, particles or visible residues remain.

For oil-adjuvanted, emulsion-based or highly viscous injectables, repeat the detergent cleaning step and final rinsing step if the jet is not clean and continuous or if residues are still visible.

Do not leave detergent, isopropanol or other cleaning fluids inside the device after cleaning. Always finish internal cleaning with clear demineralized water or PBS.

Isopropanol may be used as an additional short flushing or disinfection step after detergent cleaning. If isopropanol is used, always perform a final rinsing program with clear demineralized water or PBS afterwards.

Isopropanol should not be used as the only cleaning medium after oil-adjuvanted, emulsion-based, viscous or polymer-containing injectables.

### b. Storing the device

For **storing** the device we recommend to **add** a drop of **pharmaceutical lubrication oil** (supplied in the box) to the inlet at the fluid path **to cover the valves to prevent sticking**.



1. Place the power unit laying secure on a table and disconnect the connection line and the injection tube.
2. Start the rinsing program by pushing **both display buttons** at the **same time** for 3 seconds. This way, the device will automatically perform ten (10) rinsing cycles in a row without any further action required. This process will start only when the device is not loaded and the home screen is shown.
3. During the rinsing process, take the pharmaceutical lubrication oil and add a three drops to the inlet of the fluid path to cover the valves in the power unit.
4. Remove the battery and proceed with the outside cleaning

### c. Cleaning of the power unit

- ⚠️ Prior to cleaning your device from the outside, **remove the battery (!)** at the middle of the power unit.
- ⚠️ For the cleaning of the power unit, remove the tube.
- ⚠️ The below mentioned cleaning procedure should be carried out after **each** vaccination session.
- ⚠️ The device is **dust-protected** and **protected against water jets** (e.g., rain, splashes, washing down with a normal hose).
- ⚠️ **Do not** immerse the device in water and **do not** clean it with a high-pressure washer or steam jet. Definition of IP56:  
The device is protected against limited dust ingress (no harmful deposits) and water jets from any direction.  
It is not fully dust-tight and not suitable for immersion.



- ⚠️ Make sure you close/ cover the connector for the powerline if this is disconnected.
- ⚠️ Do not disconnect the liquid sensor cable



Remove all organic material from the device manually by using disinfection wipes or a clean, wet towel.

After cleaning, dry the device with a clean paper cloth and disconnect the high pressure tubing

Make sure the power unit is completely dry before putting it back into the case

### d. Cleaning of the Injection unit

- ⚠️ For the cleaning of the injection unit, remove the high pressure tube.
- ⚠️ The below mentioned cleaning procedure should be carried out after **each** vaccination session.
- ⚠️ The device is **dust-protected** and **protected against water jets** (e.g., rain, splashes, washing down with a normal hose).
- ⚠️ **Do not** immerse the device in water and **do not** clean it with a high-pressure washer or steam jet. Definition of IP56:

The device is protected against limited dust ingress (no harmful deposits) and water jets from any direction.

It is not fully dust-tight and not suitable for immersion.

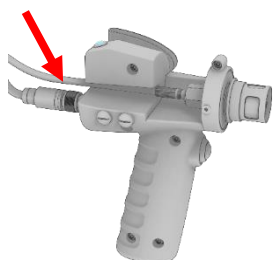

⚠ Make sure you close/ cover the connector for the powerline if this is disconnected.

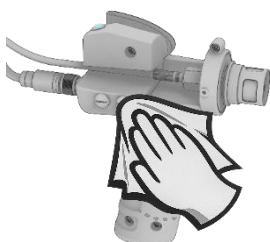

Remove all organic material from the device manually by using disinfection wipes or a clean, wet towel.

After cleaning, dry the device with a clean paper cloth and disconnect the high pressure tubing

Make sure the power unit is completely dry before putting it back into the case

#### e. Cleaning of the Connection line

- ⚠ For the cleaning of the connection line, disconnect the power unit and the injection unit.
- ⚠ The below mentioned cleaning procedure should be carried out after **each** vaccination session.
- ⚠ The high pressure tube should not be bend because this could lead to breaking of the tube
- ⚠ Check after every cleaning if the tube shows any signs of damage if so please exchange the tube.
- ⚠ Don't use steam cleaning
- ⚠ Always store the connection line disconnected from the power and injection unit to make sure it is ventilated

- Remove all organic material from the unit manually by using disinfection wipes or a **clean**, wet towel.
- After cleaning, dry the unit with a clean paper cloth.
- Make sure the injection unit is **completely dry** before putting it back into the case.

## 11. Troubleshooting

Prior to sending a device to repair, always try below mentioned steps in case of any technical issues with your HSW Jet-PACC<sup>one</sup> device.

What to do if you have the device is showing Air detecting. This is most likely related to the inlet and/or outlet valve.

### a. Guidance

Please follow this guidance to solve an issue with the air detection warning:

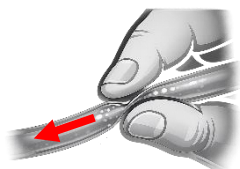

1. Connect the prefilled tube to the device. Press the trigger and try to rinse the device. During the loading press the tube and push forward the liquid to the device like shown in the picture  
Inlet valve is not opening



2. Disconnect the high pressure tube and place a drop of white oil at the outlet of the connection of the high pressure tube and start to rinse.  
Outlet valve is not closing



3. ⚠️ Keep on rinsing Take the supplied multitool and do ⚠️ very small impacts on the inlet valve ⚠️



4. Check O-rings and outlet valve at the power unit and replace if broken

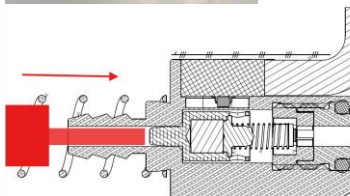

5. Check the liquid sensor first with the troubleshooting tool supplied if the swimmer is moving freely (no force needed). Try again.



6. Unscrew the inlet valve including the liquid sensor. Unscrew the inlet valve from the liquid sensor. Take the troubleshooting tool and pierce the inlet valve with the tool.



7. Dismount the sensor, clean and mount again.

8. Dismount the spare part cylinder and check for any defects clean and lubricate and mount again.

## b. Air Detection Override

### Purpose

The HSW Jet-PACCon is equipped with a fluid detection sensor to help ensure that no air is aspirated or injected during operation. Under certain field conditions, repeated air detection warnings may occur, for example due to insufficient cleaning, contamination of the valve system or sensor area, or a temporary malfunction in the fluid path. In such cases, the Air Detection Override allows temporary continuation of the current session under increased operator attention and device monitoring.

### What the Air Detection Override does

When Air Detection Override is activated, the device temporarily disables the automatic blocking function related to the air detection warning for the current session only. The device does not return to normal operation; instead, it enters a monitored override mode.

In this mode:

- the operator must regularly check jet quality and dose delivery,
- the device evaluates every shot using internal event monitoring,
- shots are classified as either **normal shot** or **suspected dry shot**,
- warnings and escalation messages may be shown if repeated anomalies occur,
- all override-related events are stored in the session data.



**Important:** Air Detection Override is a temporary recovery function. It is not intended for routine operation and does not replace correct cleaning, rinsing, maintenance or troubleshooting of the device. The device must be checked and restored to normal operating condition as soon as possible.

### Activation

Air Detection Override can only be activated after an air detection warning has occurred. To activate the override, the operator must confirm the warning message on the display.



The following warning is shown when override mode is activated:

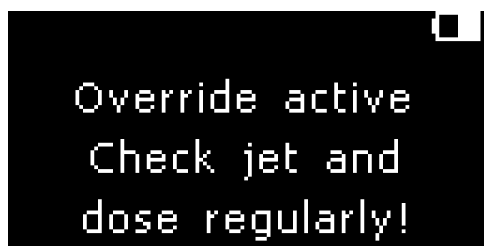

**“Override active. Check jet quality and dose regularly.”**

Once confirmed, the device remains in Air Detection Override for the current session only.

### Monitoring during override mode

During Air Detection Override, each shot is monitored by the device. If the device detects an abnormal injection event, the shot is classified as a **suspected dry shot**.

The following escalation concept applies:

Check jet quality	after <b>3 anomalies total</b> Check jet quality
Verify dose and rinse device	after <b>5 anomalies in 10 shots</b> Verify dose and rinse device
Stop session Check valve system Risk of dev. damage	after <b>8 anomalies in 10 shots</b> Stop session. Check valve system immediately. Continued operation may damage the device and may void the warranty.

- ⚠ If repeated anomalies occur, the operator must stop using the device and inspect the valve system, fluid path and cleaning status before continuing. Continued operation despite repeated warnings may lead to incomplete injections, contamination-related malfunction, or damage to the device. The troubleshooting and maintenance sections of this manual must be followed.

### **Automatic end of override mode**

Air Detection Override ends automatically in the following situations:

- device restart,
- battery change,
- successful revalidation after rinsing.

Successful revalidation is achieved only when the device detects proper fluid flow again during the defined validation sequence.

After the override has ended, the device returns to the normal air detection protection logic.

### **Stored session data**

The following information is stored as part of the session data when Air Detection Override is used:

- Air Detection Override activated
- timestamp
- shots in override mode
- anomaly count
- override ended / session ended

These records may be used for diagnosis, support and service evaluation. The stored data can support troubleshooting together with the session information and diagnostic functions of the device / app.

### **Operator responsibility**

The operator remains responsible for verifying correct application during override mode.





If jet quality is abnormal, if repeated suspected dry shots occur, or if the device shows signs of blockage, contamination or valve malfunction, the session must be stopped and the device must be checked according to the troubleshooting and maintenance instructions.

- ⚠ Air Detection Override must only be used by trained personnel familiar with the device and its warning signals. The function must not be used to bypass regular cleaning, rinsing or maintenance procedures.

Problem	Cause	Solution
Air detection.	<ul style="list-style-type: none"> <li>- Incorrect handling of the injection bottle – moving or shaking the injection bottle to often/ hectic during the loading procedure of a new dose.</li> <li>- Bottle change.</li> <li>- Air in the tube</li> <li>- Cleaning – if the device is not cleaned thoroughly, the sensor can become dirty and cause a not free movement.</li> <li>- Cleaning – if the device is not cleaned thoroughly, the inlet valve can become dirty and cause air to enter the system.</li> <li>- Cleaning – if the device is not cleaned thoroughly, the spring/valve can become dirty and cause air to enter the system through the front of the nozzle.</li> <li>- Cylinder Service – likewise during cylinder service the spring, valve or O-ring may be placed incorrectly on the cylinder which will cause air to enter the system through the front nozzle.</li> <li>- Storage over longer period of time (12+ months)</li> <li>- not connected liquidsensor</li> <li>- damaged liquidsensor</li> </ul>	<p>No hectic movements</p> <p>Make sure to hang the injection bottle freely in the bottle net to your shoulder, that it is always pointing downwards.</p> <p>If the system still detects some air check the inlet valve of the system see maintenance.</p> <p>If yes, remove the high pressure tube and press the both display buttons to start a cleaning cycle. Check if the valve system in the power unit is working well and liquid is coming out of the opening of the high pressure tube.</p> <p>If yes, mount the high pressure tube and also start the cleaning cycle.</p> <p>Check if the Liquid sensor cable is connected to the power unit.</p> <p>Check the liquid sensor if the internal part is moving free, if not demount as described in the user manual and clean. Reassemble and try again.</p> <p>If the air detection message appears permant and you see a constant flow coming out of the nozzle, please contact Henke-Sass, Wolf.</p> <p>While drawing up a new dose, cover the nozzle opening with a piece of rubber (e.g. eraser or touch pencil for a tablet) and make sure NOT to push the sleeve backwards over the nozzle at the same time. As soon as the dose has been drawn up, remove the piece of rubber from the nozzle outlet before the device ejects the drawn-up liquid. (Rinsing is taking place at very low pressure, there is no risk for injuries.)</p> <p>In addition, check the gasket on top of the cylinder as well as the valve below the injection head for contaminations and ensure they are clean and that spring and valve are positioned correctly.</p> <p>If the above mentioned steps do not help, perform a cylinder service.</p>
Injection is not successful / not possible.	Dirty / filthy injection head / jet outlet.	Clean injection head.)
	Malfunctioning cylinder.	Perform Cylinder Service.

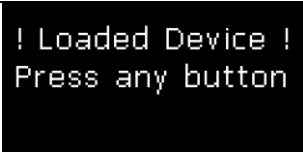
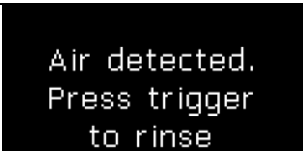
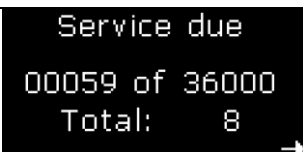
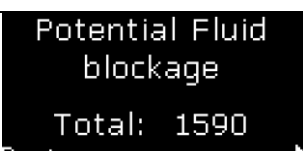
	Application error.	Place injection head perpendicularly on the animal skin.
When cleaning internally, after 10 cycles, little / no rinsing fluid comes out of the injection head.	Air inside the system.	Follow troubleshooting guide for air detection.
	Pump is not working.	Return the device to supplier.
	Vial not properly positioned.	Remove the vial and re-position it on the spike inside the bottle holder.
The safety sleeve around the injection head remains jammed following vaccination.	Dirty / filthy injection head.	Clean injection head.
	Possible damage to the injection head or to the safety sleeve.	Release the trigger immediately, remove the battery and perform exchange of injection head using the appropriate spare part (not included).
A lot of vaccine on the skin of the animal and no puncture visible (as mentioned, it is normal that a small residue of vaccine will remain on the animal's skin).	Air inside the system.	Rinse the device with rinsing fluid. During the pump process, hold the device horizontally, during the rinsing process, hold the device vertically (pointing upwards). Repeat this procedure 10 times. (see 10.1)
	Dirty / filthy injection head / jet outlet.	Clean injection head. (see 10.2)
	Blocked Nozzle	Check the beam when doing a rinsing cycle, if this is not a nice straight line check the outlet of the nozzle if something is stuck inside. Remove the part and try again.
It is not possible to unscrew the bottle adaptor from the thread of the device.	Vaccine has leaked into the thread and dried.	Try normal cleaning procedure. Do not try to loosen it with a tong / pipe wrench, because it would break the bottle holder off the device.

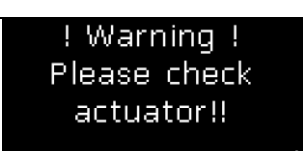
Display Indication:

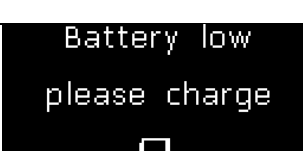
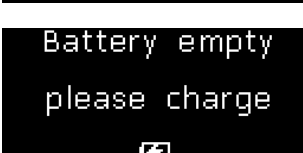
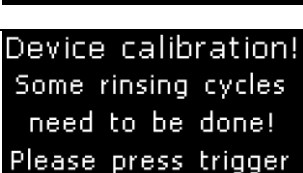
Problem	Cause	Solution
	Device was shut down loaded	Point the handle to the ground and press the trigger
	The devices detected air in the tubing	If the injectable is empty change the injectable. If the injectable is still full rinse and try to inject again. If still the error message appear see the trouble shooting section.
	The service counter records 36,000 shots: a service is required.	Perform Cylinder Service.
	Warning because of potential fluid blockage or actuator issue	Check if fluid is coming out of the nozzle, if yes press the left button to reset. If not check the tube and valve system.
		
		
		
	The battery has to be charged. Vaccination is still possible.	Fit a charged battery into the device and recharge the empty one.
	To ensure that the battery lasts a long time, never completely discharge it. This prevents the device from malfunctioning and indicates on the display when the battery is empty, rather than the battery itself. The device indicates that the battery is empty, but two LEDs on the battery are still lit.	
	For some reasons it is necessary to do a device recalibration.	By pressing the trigger a complete rinsing cycle is performed and device tries to move the actuator into 2ml position

Air detected.	Air was drawn into the device.	Rinse device at least three (3) times. If this doesn't solve the issue, follow the troubleshooting guide.
Please release nozzle	Contact with animal after injection was kept upright.	Release device from the animal.
! Warning ! Early Release	Device was released from the animal too early.	Revisit vaccination technique.
Shutting down device now...	Device is shutting down, because battery level is lower than 17.5V	Reload battery

CAUTION: In case of a necessary return of the device to the manufacturer, please **remove the batteries from the case** (as per dangerous goods regulation of all common forwarders)!

## 12. Maintenance and Repair

### a. Preparation servicing and maintenance

- ⚠ Always make sure you have disconnected the battery from the device when doing a service or a maintenance. Place the power unit on a solid surface in the recommended position



Dismount the high pressure tube from the power unit by using the supplied multitool by turning counterclockwise.



Unscrew the power line by hand (do not use any tool for mounting and dismounting).

## b. Preventive Maintenance

To keep the system running without any issues we recommend to do some preventive maintenance to the service part. This only means to lubricate the cylinder on a regular base (once a month) to secure a smooth process. This service is much dependend to how many vaccinations are done per day and also to the vaccine used. Please follow the instruction below **without exchanging** the cylinder, **only lubricate**.

## c. Cylinder Service after 36.000 injection

Service of the HSW Jet-PACC<sup>one</sup> is required after 36,000 injections. When service is due, the message “Service due” will appear on the HSW Jet-PACC<sup>one</sup> display.

For maintenance, the cylinder needs to be replaced by the included spare cylinder and the multitool (or using a 22 mm, a 14 mm wrench). Maintenance should be done in a clean environment.

Always remove the Injection tube as well the electrical line from the power unit before doing the service.

- ⚠ This step-by-step instruction is in addition to the user instructions delivered with the HSW Jet-PACC<sup>one</sup> device. Please read the user instructions carefully before operating the device and/or performing cylinder service.
- ⚠ Always remove battery before doing the cylinder service!

Make sure, that no bottle with rinsing/cleaning fluid is placed in the bottle holder of the device.

### Step 1: Unscrew injection head



Carefully unscrew the tube connection head with the supplied multitool or a 22 mm wrench and remove the tube connection head.

Remove the valve (valve body and spring)

- ⚠ As soon as injection head and valve are dismounted: Ensure that the exposed tip of the HSW Jet-PACC<sup>one</sup> is protected from dirt.

- ⚠ Hold the device with the head facing downwards in order to drain residues of vaccine or rinsing fluid.

### Step 2: Remove old cylinder



Unscrew the old cylinder with the multitool.



Hold the device with the head facing downwards and only then (!) remove the cylinder from the device by pulling (you could use the multitool as shown). This will allow you to drain remaining vaccine or rinsing fluid.

### Step 3: Clean cylinder mount and Lubricate the piston rod



Please take a Q-tip or similar (e.g. wooden / metal stick wrapped with absorbent cotton), dip in isopropanol (or similar high-grade alcohol disinfectant), insert into the chamber and wipe the walls to clean / disinfect them, which will neutralize the smell of the vaccine residues. However, please make sure not to use too much isopropanol because any excess amount of liquid flows to the back of the device and can damage the internal components. Thus, ideally hold the device in a slight decline when cleaning the chamber, like pictured below (Q-tip / stick with absorbent cotton marked red [stick] and green [cotton]):



Prior to lubrication, clean the piston chamber and piston rod by wiping it with a clean cotton cloth or clean Q-tip/cotton bud. Lubricate the tip of the piston rod using a fingertip or Q-tip/cotton bud soaked in the supplied white oil.

#### Step 4: Insert new cylinder



Lubricate the o-rings on the exterior wall of the new cylinder with white oil.

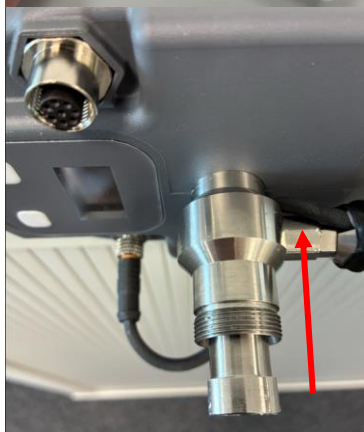

Insert the new cylinder into the opening of the piston chamber and push down until it sits firmly.



Push the new cylinder down (with your finger) until the thread engages. Then tighten the cylinder clockwise with the multitool or a 15mm wrench until you feel a significantly increased screwing resistance. Alternatively use a torque wrench set to 1.8 Nm.



Place the device in a upright position and place the valve and the spring as shown in the picture.



Take the tube connection head and reassemble it with the multitool clockwise.

#### Step 5: Flush & shoot

- Connect the connection line with the injection unit to the new serviced Power unit and fit a bottle with rinsing/cleaning fluid into the holder and rinse until a clean and continuous jet is coming out of the injection head of the injection unit.
- Simulate 10 injection cycles by shooting into a clean towel. This optimally aligns the valve and the spring.

#### Step 6: Check functionality

- If the injection head is not operating properly (no clean and continuous jet of rinsing fluid is coming out), please repeat cylinder service by exactly following above mentioned steps.

#### Step 7: Reset Service Counter



- After successful completion of cylinder service, please reset service counter.
- Starting from the home screen, push the right button three times until reaching menu point "Service Counter".
- Push button "Reset" for at least 3 seconds.
- The counter returns to "0".

#### d. Cleaning and checking the outlet valve in the injection unit

In some cases it could be that the injection head of the injection unit is clogged by some particles. To clean the outlet valve and injection head please see below the guideline how to proceed.

Maintenance should be done in a clean environment.



Disconnect the power line from the handpiece by turning the metal part counterclockwise. Never use any tools for doing that.



Disconnect the high pressure tubing from the handpiece by using the supplied multitool or using a 14 wrench. Turn the metal piece counterclockwise and disconnect the tubing. Always make sure the tube is not damaged.



For dismantling the injection head use the multitool as shown in the picture. Turn the head counterclockwise till the part can be lift away. Please pay attention to small parts.

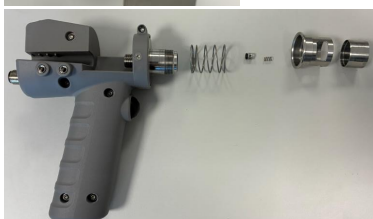

Check all parts and clean them and assemble it again as shown below.

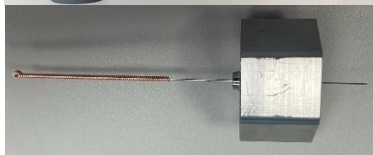

If the Nozzle is clogged, use the supplied acupuncture needle and try to remove the clogging from the outside of the nozzle to the inside as shown in the picture.

Connect the high pressure tubing and use the multitool turning the metal part clockwise. Never use too much force to mount the high pressure tubing because you could damage the parts. Connect the power line by screwing the metal piece by hand clockwise.

#### e. Cleaning and checking the fluidsensor and inlet valve

In some cases it could be that the fluidsensor and/ or the inlet valve are not working properly because of not cleaning the device correct. If so please proceed as described below.



Disconnect the fluid sensor cable by turning the metal part counter clockwise.



For unscrewing use the multitool and not a forceps because you could damage the safety sleeve around the sensor. Just loosen the sensor incl. the inlet valve with the tool and then use your hand and turn the sensor counterclockwise.

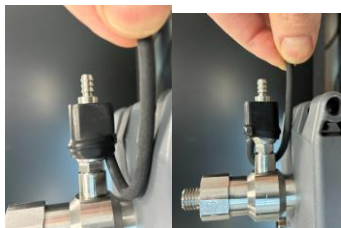

When turning the sensor don't bend the cable too much, this could damage the sensor. As shown in the pictures, help the cable that the sensor can be turned easily.

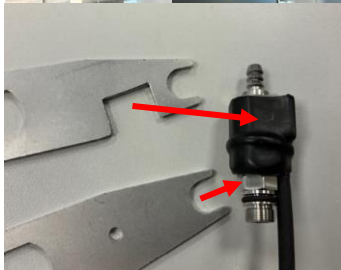

To disconnect the inlet valve from the fluid sensor use two multitools as shown in the picture. Hold the black part with the big opening and use the small opening for the inlet valve.



The inlet valve cannot be further disassembled. If the inlet valve is clogged, use a needle or something similar to loosen the small ball inside. You could also place this part into some cleaning fluid and let it soak.

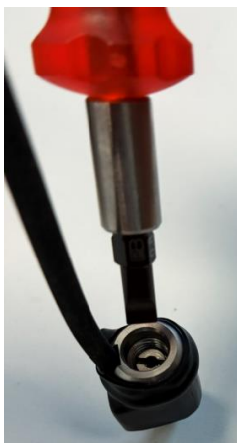

Opening the Sensor is only necessary if you face some issues with the sensor. For example when the sensor shows you that it has detected air but liquid is coming out properly.

For checking the Fluidsensor you can open it up by using a flat screw driver as shown in the picture. Hold the outside with your finger and turn the screw counter clockwise.

Pay attention small parts could drop to the ground!!!



Clean everything up and mount it back as shown in the picture.

Please keep in mind this is a sensor



Please make sure the white part and the spring is mounted as shown in the picture. Take the small metal part and screw it inside handtight.



Screw in the inlet valve into the fluid sensor. Take the combination and mount it back to the device.



Take the combination and mount it back to the device.  
Pay attention to the cable when screwing the combination back in.

### 13. Dismantling

The HSW Jet-PACC<sup>one</sup> device may only be dismantled by authorized service engineers. In case of unauthorized dismantling, the device will lose its warranty.

**⚠** Do not open the HSW Jet-PACC<sup>one</sup> device by yourself due to health and safety risks!

## 14. The battery and the charger

### a. Battery

The battery of the HSW Jet-PACC<sup>one</sup> is a rechargeable Lithium Ion (Li-Ion) battery. At least 2,000 injections can be administered by using a fully functioning and charged battery.

To ensure that the battery lasts a long time, never completely discharge it. This prevents the device from malfunctioning and indicates on the display when the battery is empty, rather than the battery itself. The device indicates that the battery is empty, but two LEDs on the battery are still lit.

- ⚠ Use only appropriate batteries in the HSW Jet-PACC<sup>one</sup>. The use of other batteries can lead to injuries and fire hazard.
- ⚠ Do not expose the battery to mechanical shocks.
- ⚠ Stop using the battery if it becomes abnormally hot, or if discoloration, deformation or abnormal conditions are detected during use, charge or storage.
- ⚠ Replace the battery when its running time between charges becomes much shorter than usual.
- ⚠ It is recommended that batteries are not recharged before falling below 50% loading capacity.
- ⚠ Never store empty batteries as this could damage them and make them unusable.
- ⚠ Never send/ ship defective batteries to any destination. Instead, please dispose of them correctly.



The battery of the HSW Jet-PACC<sup>one</sup> is a rechargeable Lithium Ion (Li-Ion) battery. At least 2,000 injections can be administered by using a fully functioning and charged battery.



At the back of the battery there is the status indicator. By pressing the white button the LED indicate the loading state of the battery.



The battery should be slotted into the opening at the middle of the power unit of the HSW Jet-PACC<sup>one</sup> device.



Take the battery and slide it in gently as shown in the picture till you hear a click.



A fastening button will hold the battery in position. The battery can be removed from the power unit by pushing down the button at the front of the battery and by pulling out the battery.

## b. Charger

Charge the battery using only the charger supplied. Connect the battery to the charger and connect the charger to an electric socket. When connected correctly, the charging process will start automatically.

- ⚠ Check the charger regularly for damage, especially the connection cable and the housing. Do not use damaged battery chargers.
- ⚠ Always grasp the plug, not the cable, when removing the mains plug from the socket.
- ⚠ Faulty electrical installation or too high mains voltage can lead to electric shock. Only connect the battery charger to an easily accessible socket, so that you can quickly disconnect it from the power supply in the event of fault.
- ⚠ If you charge the battery improperly, the battery, battery charger and the HSW Jet-PACC<sup>one</sup> device may be damaged. Charge the battery at an ambient temperature between 0°C and 45°C.
- ⚠ Only connect batteries of the HSW Jet-PACC<sup>one</sup> with the charger other batteries could get damaged when using the wrong charger.

The LEDs have the following functions:

Connect the cable of the charger with the battery as marked.



LED lights orange:

Battery is empty and charging.



LED lights yellow:

Battery is partly charged and still charging.



















LED lights green:

Battery is fully charged.

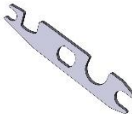

- ⚠ The battery charger is not waterproof!
- ⚠ Operate the battery charger indoors only!

## 15. Spare Parts

Description	Number	
Power unit	8300065977	
Injection unit	8300066472	
Connection cabel	8300066483	
Connection tube incl. angle piece	8300066204	
Cable Clip 2-way	8300066482	
Battery 5S1P 18V	8300067446	
Charger 18V	8300067859	
Bottle PET 250ml + Cap	8300019267	
	8300017876	
Lubrication oil 10ml bottle	8300027303	
Silicon Tubing 2m	3532000600	
Back straps	8300067496	
Bottle net 250ml	8300067497	
Snap hook	8300067498	
Draw-Off Cap white 20mm, 50-100ml	3600000020	
Draw-Off Cap blue 30mm, 250-500ml	3600000030	
Draw-Off Cap green 33mm, > 500ml	3600000033	
Threaded bottle adapter to hose	8300067772	
Wrench for Jet-PACC	8300068054	
Spare cylinder	8300065482	
Spare part set (valve + O-ring)	8300067768	
Hose clamp	8300068944	
Waist strep	8300069346	

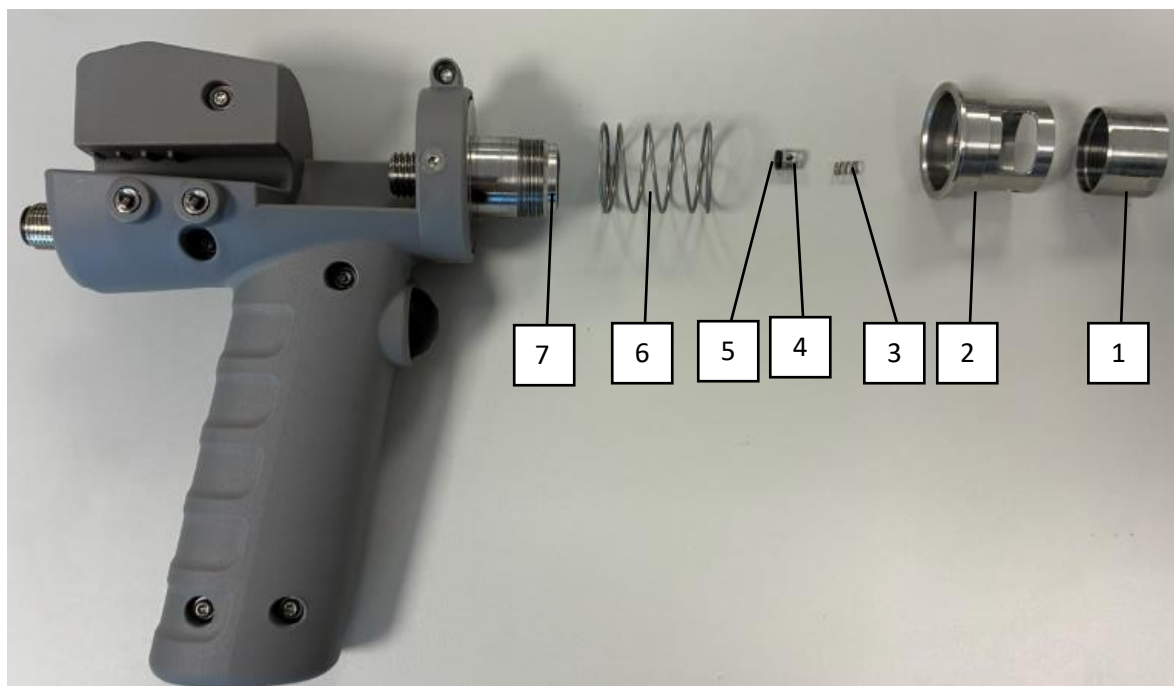

<b>Part</b>	<b>Description</b>	<b>Number</b>
1	Injection Nozzle	8300068844
2	Safety Cage	8300068249
3	Valve spring	85202099
4	Valve body	8300068606
5	Valve O-Ring	8300017948
6	Spring safety cage	8300051349
7	Injectionhead O-ring	8300066473
8	Belt Clip (not visible)	8300036990

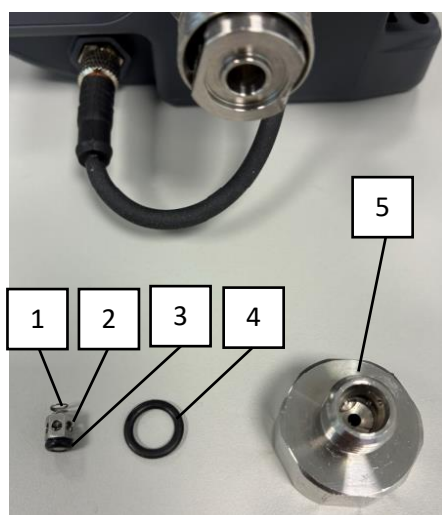

<b>Part</b>	<b>Description</b>	<b>Number</b>
1	Valve spring	85202099
2	Valve body	8300068606
3	Valve O-Ring	8300017948
4	Valve body	8300055858
5	Connection tube	8300065448

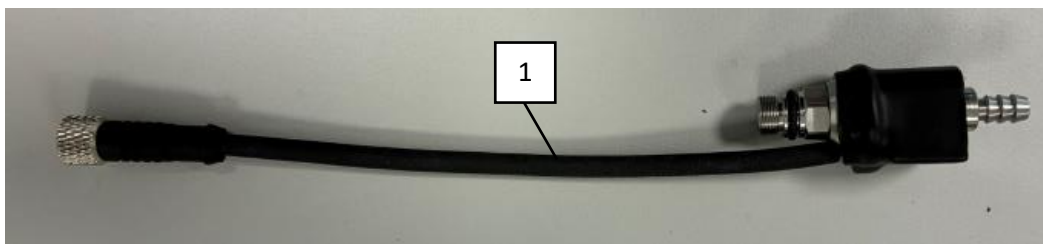

<b>Part</b>	<b>Description</b>	<b>Number</b>
1	Fluidsensor incl. inlet valve	8300065588

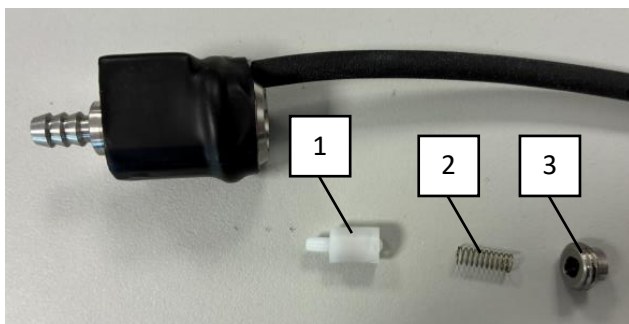

<b>Part</b>	<b>Description</b>	<b>Number</b>
1	Swimmerbody	8300068846
2	Spring	85215699
3	Closure swimmer	8300067744

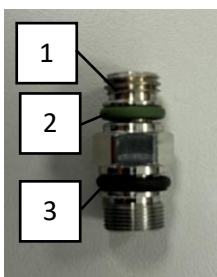

<b>Part</b>	<b>Description</b>	<b>Number</b>
1	Valve incl. housing	8300068847
2	Green O-ring	3002000810
3	Black O-Ring	8300052955

## 16. HSW Connect App

The HSW Connect app allows users to customize smart vaccination devices, manage relevant device data and reports, access support and updates, and check functionality through on-demand diagnostics.

QR Codes:



The HSW Connect App has four major functionalities:

1. Customization and Control:
  - Customization of device settings based on needs and preferences
  - Display of sensor values and adjustment of settings (depending on the device)
2. Data Management and Reporting:
  - Transmission and management of device data (e.g., number of vaccinated animals, doses administered, vaccine used)
  - Creation and export of transparent reports via email
3. Diagnostics and Maintenance:
  - On-demand self-diagnosis to check device functionality
  - Remote software updates for the device
4. Support and Documentation:
  - Direct access to user manuals and support
  - Direct service contact option

To learn more on what sort of failure occurred, download the HSW Connect App for iOS or Android. Run a self-diagnosis by starting the App, connecting the App to your device and thereafter pushing the button “Run diagnosis” in the App.

## 17. Technical Specifications

### HSW Jet-PACC<sup>one</sup>

Model: 103

Weight: 4485 g (Injection unit 390 g) (Power Unit 3550 g) (Connection line 165 g) (Battery 380 g)

Dimensions: 360 x 106 x 173 mm (with assembled battery)

### Battery

Voltage: 18 VDC

Capacity: 3000mAh (54Wh)

Type: Lithium-Ion rechargeable Cell

Weight: 380 g

### Charger

Protection Class: 2

Type: Lithium-Ion battery charger

Input Voltage: 100-240VAC, 50-60 Hz

Input Current: max 1.6A

### Compliance statements

CE, RoHS, FCC & IC certified

## 18. Disposal

The HSW Jet-PACC<sup>one</sup> device, batteries, accessories and packaging should be sorted for environment-friendly recycling.

Do not dispose of power tools and batteries/rechargeable batteries into household waste!

Applicable in the EU

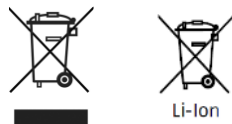

Old appliances must not be disposed of with household waste!

Batteries and rechargeable batteries must not be disposed of with household waste!

According to the European Guideline 2012/19/EU, power tools that are no longer usable, and according to the European Guideline 2006/66/EC, defective or used battery packs/batteries, must be collected separately and disposed of in an environmentally correct manner.

## 19. UKCA – Conformity marking

With the UKCA mark, the legal manufacturer declares compliance with Great Britain (UK) regulation.

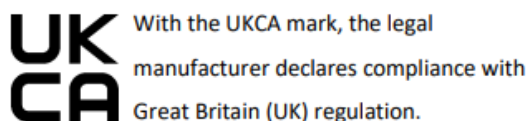

## 20. EC declaration

	<b>Konformitätserklärung / Declaration of Conformity</b>	Seite / Page	1 von 1
		Produktgruppe / Product group:	HSW Jet-PACC <sup>oem</sup>
		Revisionsstand / Revision status: --	Revisions-Datum / Revision date: 24.03.2026
<small>Alle Rechte vorbehalten. Ausgabe als PDF nur mit Genehmigung von GULU/GM. All rights reserved. Copies for third parties only by permission of GULU/GM. Tous droits réservés. Des copies à des tiers sont interdites sans la permission de GULU/GM.</small>			

Wir, die HENKE-SASS, WOLF GmbH, Keltenstrasse 1, 78532 Tuttlingen erklären in alleiniger Verantwortung, die Übereinstimmung mit den folgenden Richtlinien:

- EMV-Richtlinie 2014/30/EU
- Niederspannungsrichtlinie 2014/35/EU
- Maschinenrichtlinie 2006/42/EG
- Maschinenverordnung 2023/1230/EU
- Funkanlagenrichtlinie (RED) 2014/53/EU
- Richtlinie 2011/65/EU zur Beschränkung der Verwendung bestimmter gefährlicher Stoffe in Elektro- und Elektronikgeräten

We, the HENKE-SASS, WOLF GmbH, Keltenstrasse 1, 78532 Tuttlingen declare in our own responsibility the conformity to following directives:

- EMC-Directive 2014/30/EU
- Low Voltage Directive 2014/35/EU
- Machinery Directive 2006/42/EG
- Machinery Regulation 2023/1230/EU
- Radio equipment directive (RED) 2014/53/EU
- Directive 2011/65/EU on the restriction of the use of certain hazardous substances in electrical and electronic equipment

Diese Konformitätserklärung ist gültig für folgende Produkte:

This Declaration of Conformity is valid for following Products:

HSW Jet-PACC<sup>oem</sup>

Die Produkte stimmen mit folgenden Normen überein:

The products are conforming to following standards:

- EN ISO 12100
- EN 55032
- EN IEC 61000-3-2
- EN 61000-3-3
- EN 61000-4-2
- EN IEC 61000-4-3
- EN 61000-4-4
- EN 61000-4-5
- EN 61000-4-6
- EN IEC 61000-4-11
- ETSI EN 301 489-1 v2.2.3
- ETSI EN 301 489-17 v3.3.1

**HENKE-SASS, WOLF GMBH**  
Keltenstraße 1  
**78532 TUTTLINGEN**  
GERMANY  
Tel. +49(0)7462/9466-0 · Fax 07462-5000

Tuttlingen, den 24.03.2026

Ort und Datum der Ausstellung  
Place and Date of issue



Robin Sauter  
Direktor Innovation  
& Qualität  
Director Innovation &  
Quality

Firmenstempel  
Company Stamp

## 21. FCC Regulatory Compliance

This device complies with Part 15 of the FCC Rules. Operation is subject to the following two conditions:

- (1) This device may not cause harmful interference, and
- (2) this device must accept any interference received, including interference that may cause undesired operation.

**Warning:** Changes or modifications not expressly approved by the party responsible for compliance could void the user's authority to operate the equipment.

**Note:** This equipment has been tested and found to comply with the limits for a Class B digital device, pursuant to Part 15 of the FCC Rules. These limits are designed to provide reasonable protection against harmful interference in a residential installation. This equipment generates, uses and can radiate radio frequency energy and, if not installed and used in accordance with the instructions, may cause harmful interference to radio communications. However, there is no guarantee that interference will not occur in a particular installation.

If this equipment does cause harmful interference to radio or television reception, which can be determined by turning the equipment off and on, the user is encouraged to try to correct the interference by one or more of the following measures:

- Reorient or relocate the receiving antenna
- Increase the separation between the equipment and receiver
- Connect the equipment into an outlet on a circuit different from that to which the receiver is connected
- Consult the dealer or an experienced radio/TV technician for help

### FCC RF Radiation Exposure Statement

1. This Transmitter must not be co-located or operating in conjunction with any other antenna or transmitter
2. For body worn operation, this device has been tested and meets FCC RF exposure guidelines. When used with an accessory that contains metal may not ensure compliance with FCC RF exposure guidelines

Contains FCC ID: R7TAMB2621

## 22. Industry Canada (IC) regulatory information

The device contains licence-exempt transmitter(s)/receiver(s) that comply with Innovation, Science and Economic Development Canada's licence-exempt (RSS)(s). Operation is subject to the following two conditions:

- (1) This device may not cause interference
- (2) This device must accept any interference, including interference that may cause undesired operation of the device.

### Caution: Exposure to Radio Frequency Radiation

1. To comply with the Canadian RF exposure compliance requirements, this device and its antenna must not be co-located or operating in conjunction with any other antenna or transmitter.

2. For body worn operation, this device has been tested and meets RF exposure guidelines when used with an accessory that contains no metal. Use of other accessories may not ensure compliance with RF exposure guidelines.

Contains IC ID: 5136A-AMB2624

## 23. SRRC Compliance Statement (China)

HSW Jet-PACC<sup>one</sup>:

CMIIT ID: 26J99X25B254

This product has been tested and complies with the relevant regulations set forth by the State Radio Regulation of China (SRRC). The product meets all necessary requirements for operation within China's wireless communication standards, including frequency bands and transmission power limits.



**Please contact Henke-Sass, Wolf GmbH if you need any assistance or spare parts.**

Henke-Sass, Wolf GmbH  
Keltenstr. 1  
78532 Tuttlingen; Germany  
Tel. +49 74 62 94 66 0  
[www.henkesasswolf.de](http://www.henkesasswolf.de)  
E-Mail: [info@henkesasswolf.de](mailto:info@henkesasswolf.de)

800022299 06/26